

AL600/AL690 HYBRID LIFTS



OWNER'S
MANUAL



THANK YOU

From all of us at Harmar, thank you for placing your trust in our products and allowing us to be a part of your journey.

For more than 20 years we have been committed to building products that help you maintain independence. With a drive to empower people to live as they choose, Harmar Lifts Lives.

Beyond vehicle lifts, like the one you've purchased, Harmar designs and manufactures Vertical Platform Lifts, award-winning stairlifts, and more.

It is our mission to lift lives in the home and on the road.

Visit harmar.com or speak to your dealer about the other solutions available from Harmar.

TABLE OF CONTENTS

- SAFETY 4**
 - Safety Definitions 4
- INTRODUCTION 6**
 - Device Name:
AL600 / AL690 Hybrid Vehicle Lifts 6
 - Read and Understand 6
 - Technical Specifications 6
- OPERATION 7**
 - AL600: Loading and Securing a Mobility Device 7
 - Lowering the Lift Platform 7
 - Driving the Mobility Device onto the Platform 7
 - Securing the Mobility Device 8
 - AL690: Loading and Securing a Mobility Device 9
 - Lowering the Lift Platform 9
 - Driving the Mobility Device onto the Platform 9
 - Securing the Mobility Device 9
- SAFETY & MAINTENANCE 11**
 - Owner/Maintenance 11
- WARRANTY 16**



SAFETY

SECTION 1

SAFETY

SAFETY DEFINITIONS



This safety alert symbol appears with safety statements. It means attention, become alert, your safety and the safety of others are involved! Please read and abide by the message that follows the safety alert symbol.

WARNING

Indicates a hazardous situation that, if not avoided, could result in death or serious injury.

CAUTION

Indicates a hazardous situation that, if not avoided, could result in minor or moderate injury.

NOTICE

Indicates a situation which can cause damage to the lift and/or the environment, or cause the lift to operate improperly.

NOTE: Indicates a condition that should be followed in order for the lift to function in the manner intended.

If you do not understand any portion of the installation or operation procedures, please consult Harmor's Technical Service Department at 800-833-0478. Do not attempt to install or use this lift if you have any hesitation or question. Serious injury or damage can result if proper procedures are not followed.

Consider the following general information when using your lift. Specifics may vary based on your chair model and lift combination.

Always make certain your lift is fully deployed and flush with the ground prior to loading your mobility device.

Ensure you have positioned the chair properly on the platform and that it is secured on the lift before transport.

Always verify wheels are captured by cradles or aligned evenly on the platform. Also ensure the securement device is fully engaged (hold-down foot, straps, or hold-down arm). Please consult your dealer on the specifics of your application if you have questions.

Always drive slowly over rough terrain such as potholes, unpaved roads, railroad tracks, speed bumps or other uneven surfaces. Excessive loads and rough driving will damage your lift and will not be covered by the warranty.

Stop using the lift immediately if you notice any damage. Do not attempt to transport a mobility device with a compromised lift. Damage to your chair, lift and/or vehicle may occur. Contact your dealer and ask for an evaluation of the lift prior to further use.

Always check to make sure nobody is in the process of getting on or off the mobility device before operating the lift.

Always verify the mobility device is held firmly in place prior to transport.

Never attempt to move the vehicle without the lift being in the full upright or stowed position, as this may damage the lift.

⚠ WARNING

This lift is **NOT** meant for human transport. The chair or scooter **MUST** be unoccupied before operating the lift. Each lift is designed to transport a specific mobility device only. **DO NOT** attempt to move any mobility devices, objects, people, or materials other than those for which the lift was intended.

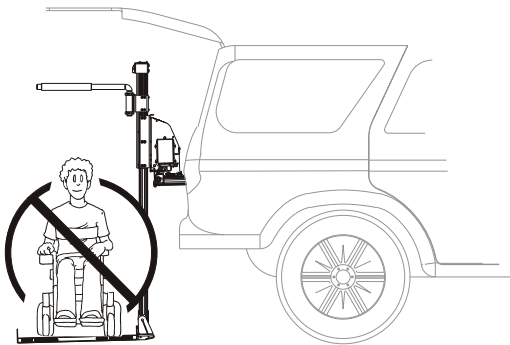

⚠ CAUTION

Do not allow anyone to use this lift unless they are properly instructed on operational and safety procedures.

⚠ WARNING

When using the lift, keep your hands and feet from under the platform.

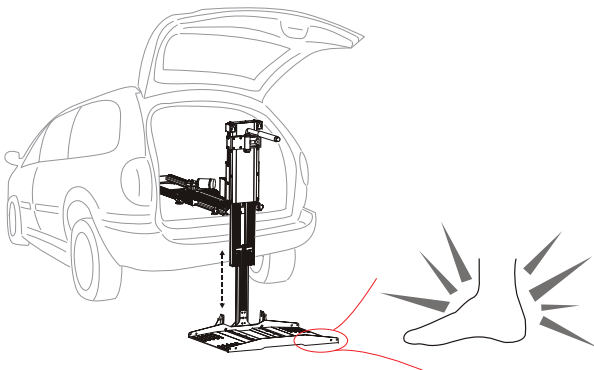

⚠ WARNING



Beware of Pinch Points. These are areas of moving parts that can catch extremities or clothing. Do not place fingers, extremities, clothing or jewelry near pinch points.

INTRODUCTION

SECTION 2

INTRODUCTION

DEVICE NAME: AL600 / AL690 HYBRID VEHICLE LIFTS

Indications of Use: The Harmar Hybrid Vehicle Lift is intended to lift, secure and transport an unoccupied mobility device for patients of mobility-impaired persons.

READ AND UNDERSTAND

This manual provides instructions for proper use and maintenance of your AL600 / AL690 Hybrid Vehicle Lift. Any alterations to the equipment without written authorization by the manufacturer is prohibited and will void the warranty.

If you have questions concerning the operation and maintenance of your Hybrid Vehicle Lift, please contact your dealer.

Please ensure that you fill out the separate warranty form and return it within ten (10) days of installation to register your lift.

TECHNICAL SPECIFICATIONS

Visit harmar.com for specifications on the specific lift model and configuration.

SECTION 3

OPERATION

AL600:
LOADING AND SECURING
A MOBILITY DEVICE

LOWERING THE LIFT PLATFORM

Using the wired hand control or optional wireless key-fob controller, lower the lift platform until it reaches the ground and becomes level.

1. Start by activating the hand control with the power button. The hand control has two operating buttons, UP to raise and stow the platform and DOWN to draw out and lower the platform, that must be depressed and held to complete the desired function. The hand control has integrated LED lights that can be used as a flashlight at night. The hand control can be aimed at the ground or at the vehicle to assist in ensuring the path is unobstructed.

See Figure 3-1

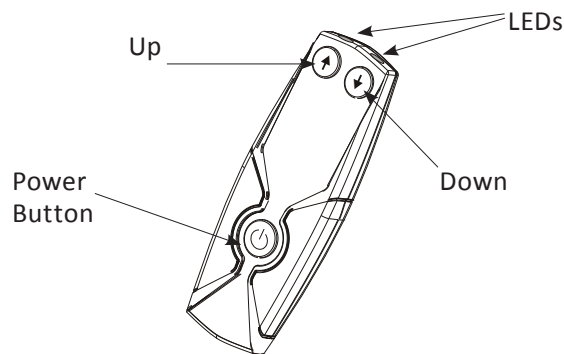

Figure 3-1

DRIVING THE MOBILITY DEVICE
ONTO THE PLATFORM

1. Determine heaviest portion of the power chair or scooter. This is usually under the drive wheels, motor(s), and batteries. Always drive onto platform with the heaviest portion closest to the lifting tower.

If loading a scooter and the platform has the AL617 Extension Plate, drive onto the platform so that the scooter's front wheels are resting on the extension plate, and rear wheels are on the main platform. This allows the heaviest portion of the scooter to be closest to the lifting tower.

Set your chair or scooter's speed control to slow speed to maneuver easily onto the platform. You can drive onto the platform from either side.

See Figure 3-2.

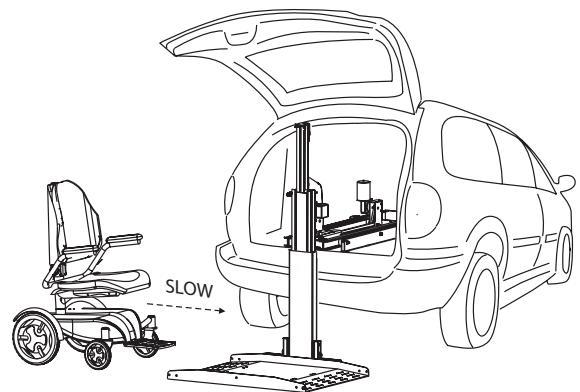

Figure 3-2

OPERATION

SECURING THE MOBILITY DEVICE

1. Each corner of the AL600 platform has a restraint attached, with a hook on the end. Place each hook in either the anchor plate slot or in each U-bolt. **See Figure 3-3**

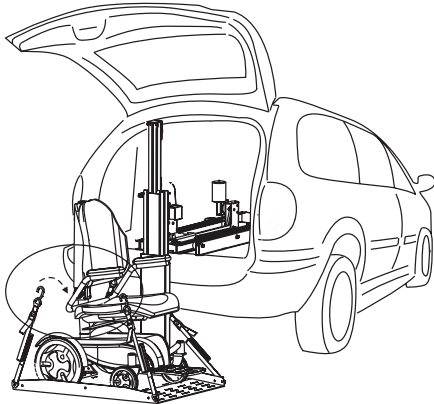

Figure 3-3

2. Pull the loose end of each restraint tight. To release, simply press the release tab and remove the hooks. **See Figure 3-4**

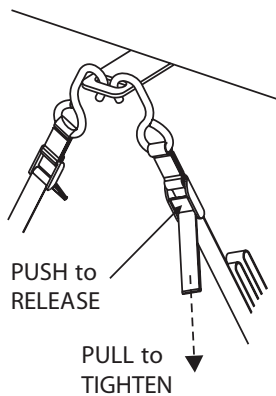

Figure 3-4

3. If your chair has a folding seat back, you may want to place it in the down position for easier clearance when loading the chair into the vehicle. Depending on the size of your chair, you may need to remove the headrest as well.

4. Use the wired hand control or optional wireless key-fob controller, to raise and retract the platform into the stowed/travel position. **See Figure 3-5.**

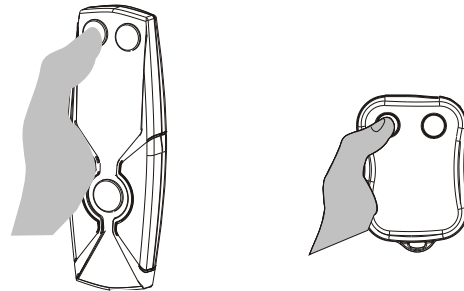

Figure 3-5

5. Double-check that the mobility device is secured properly on the platform. While holding the hand control, stand to the side and away from the lift. Press the “Up” button. When the platform stops retracting, release the button. The platform will automatically lock itself into a travel position. Close the door slowly, making sure that no part of the mobility device or other objects in the cargo area contacts the door. **See Figure 3-6.**

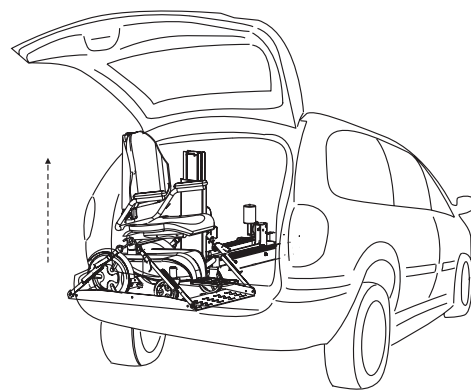

Figure 3-6

6. The wired hand control comes equipped with a magnetic back. Once the platform is completely stowed in the vehicle, simply attach the wired hand control to a metal surface for easy retrieval.

AL690: LOADING AND SECURING A MOBILITY DEVICE

LOWERING THE LIFT PLATFORM

Using the wired hand control or optional wireless key-fob controller, lower the lift platform until it reaches the ground and becomes level.

1. Start by activating the hand control with the power button. The hand control has two operating buttons, UP to raise and stow the platform and DOWN to draw out and lower the platform, that must be depressed and held to complete the desired function. The hand control has integrated LED lights that can be used as a flashlight at night. The hand control can be aimed at the ground or at the vehicle to assist in ensuring the path is unobstructed.

See Figure 3-7

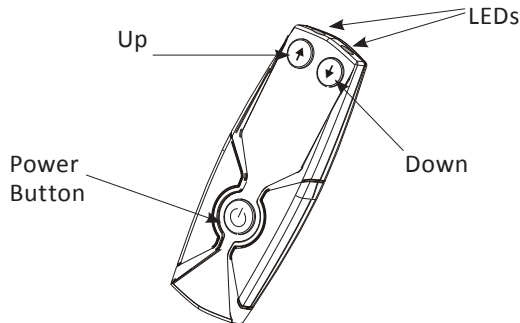

Figure 3-7

DRIVING THE MOBILITY DEVICE ONTO THE PLATFORM

1. Determine heaviest portion of the power chair or scooter. This is usually under the drive wheels, motor(s), and batteries. Always drive onto platform with the heaviest portion closest to the lifting tower. Most often this method requires the chair or scooter to be loaded in reverse, and unloaded driving forward. Set your chair or scooter's speed control to slow speed to maneuver easily onto the platform.

See Figure 3-8

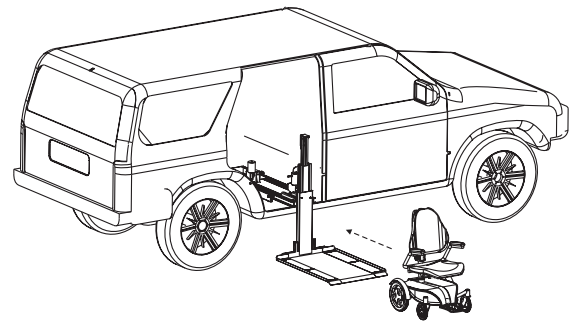

Figure 3-8

SECURING THE MOBILITY DEVICE

1. Each corner of the AL690 platform has a restraint attached, with a hook on the end. Place each hook in either the anchor plate slot or in each U-bolt. See Figure 3-6

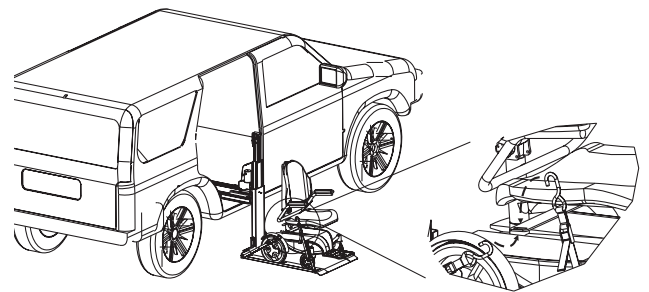

Figure 3-9

2. Pull the loose end of each restraint tight. To release, simply press the release tab and remove the hooks. See Figure 3-7

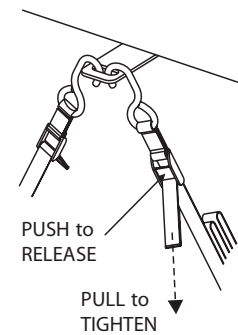

Figure 3-10

OPERATION

3. If your chair has a folding seat back, you may want to place it in the down position for easier clearance when loading the chair into the vehicle. Depending on the size of your chair, you may need to remove the headrest as well.
4. Use the wired hand control or optional wireless key-fob controller, to raise and retract the platform into the stowed/travel position.
See Figure 3-11.
6. The wired hand control comes equipped with a magnetic back. Once the platform is completely stowed in the vehicle, simply attach the wired hand control to a metal surface for easy retrieval.

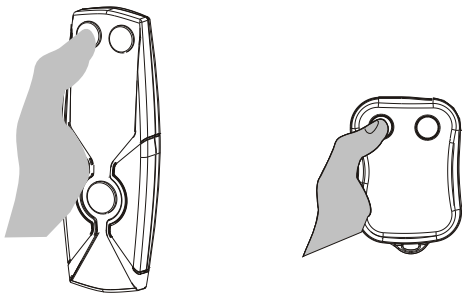

Figure 3-11

5. Double-check that the mobility device is secured properly on the platform. While holding the hand control, stand to the side and away from the lift. Press the “Up” button. When the platform stops retracting, release the button. The platform will automatically lock itself into a travel position. Close the door slowly, making sure that no part of the mobility device or other objects in the cargo area contacts the door.
See Figure 3-12

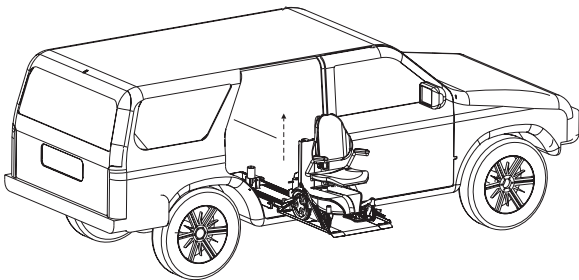

Figure 3-12

SECTION 4

SAFETY & MAINTENANCE

Except as described elsewhere in this manual, maintenance must be performed only by qualified technicians. Contact a local dealer with questions or to schedule any needed inspections, repairs, or service.

This hybrid lift is designed to be as trouble-free as possible, but as with any mechanical device, regular maintenance will help ensure that it continues to offer reliable and safe use for years to come.

We recommend that a preventative safety and maintenance inspection is scheduled with a local dealer at least once a year on motors, lift frame, wiring harness, strap integrity, and all moving parts of the lift.

- Check for paint chips and touch up bare metal. Use a good black enamel or lacquer to inhibit rust. This may need to be done more frequently if the lift is subject to salt air or road salt.

OWNER/MAINTENANCE

Before Use: Do not use lift until these conditions are rectified.

- Check for any obstructions in the path of the lift. Keep items away from aluminum channels. Hand control must not obstruct the travel area of the lift.
- Visually check lifting strap (during empty travel) before loading chair.
- Clean any debris from the platform.
- Keep hand control cord away from moving parts.
- Avoid loose items in the cargo area of the lift.
- If applicable, change wireless key-fob controller batteries annually.
- If any unusual noise or noticeable change occurs in the speed or travel of the lift, please contact your service technician.

WARRANTY



SECTION 6

3-YEAR LIMITED WARRANTY

PRODUCTS COVERED: AL600 / AL690 MODELS

The lift came with a separate warranty form on page 13. To register the lift, the warranty form must be returned within ten (10) days of installation. This warranty policy page must remain in the owner’s manual for future reference. Do not tear out this page.

Dealer/Installer Name: _____

Address: _____

Phone: _____

E-Mail: _____

The installation date and serial # of the lift will be required for the dealer to receive factory information for service or warranty work.

Installation Date: _____

Serial # of the Lift: _____

THIS EXPRESS WARRANTY IS IN LIEU OF ALL OTHER WARRANTIES OR CONDITIONS, INCLUDING ALL IMPLIED WARRANTIES OR MERCHANTABILITY OR FITNESS FOR A PARTICULAR PURPOSE, AND THERE ARE NO WARRANTIES THAT EXTEND BEYOND THE DESCRIPTION OF THE LIMITED WARRANTY DESCRIBED HEREIN. THIS WARRANTY GIVES YOU SPECIFIC LEGAL RIGHTS AND YOU MAY ALSO HAVE OTHER LEGAL RIGHTS WHICH VARY FROM STATE TO STATE.

Harmar Mobility warrants to the original purchaser of the vehicle lift manufactured by Harmar to be free of defects in material, mechanical and electrical component (parts), excluding labor costs, paint and covers, for a period of three (3) years from date of retail purchase, provided that the products have been installed and maintained by an authorized Harmar distributor or certified Harmar installer and operated properly.

This warranty does not cover defects in vehicles on which Harmar products are installed or malfunctions in Harmar products caused by defects in any part of the vehicle upon which the product is installed. This warranty does not cover maintenance or adjustments. Harmar will not be charged for labor, consequential damage or repair expenses. Harmar will not, under any circumstances, be liable for the loss of the use of its products or loss of time. This warranty becomes null and void if the product has been lost, damaged by accident, over-stressed, misused and/or neglected, or if the product has been modified in any way. Defective parts must be returned, prepaid, to Harmar, for inspection prior to credit, repair or replacement, at Harmar’s option. Harmar’s sole obligation and the exclusive remedy under this warranty is limited to such credit, repair or replacement. All warranty claims must be reported to the dealer from whom the lift was purchased as they have responsibility for handling warranty claims.

Dealers may charge for labor, service, travel, or other associated costs to make repairs, and such charges are not covered by this Limited Warranty.

All parts used to replace defective materials must be genuine Harmar parts to be covered by this Limited Warranty. This Limited Warranty grants specific legal rights, other rights vary from state to state.

PLEASE FILL OUT ALL FIELDS AND RETURN WITHIN TEN (10) DAYS OF PRODUCT INSTALLATION.

Fax completed form to 1-866-234-5680 or mail to:
Harmar, ATTN Warranty Department, 1500 Independence Blvd. Suite 220, Sarasota Florida 34234.

PRODUCT INFORMATION

Model: _____
Serial Number: _____
Purchase Date: _____
Installation Date: _____

INSTALLER INFORMATION

Company Name: _____
Contact Name: _____
Address: _____

Phone: _____
Fax: _____
Email: _____

APPLICATION INFORMATION

Scooter Power Wheelchair
 Wheelchair N/A
Year: _____
Manufacturer: _____
Model: _____

PURCHASER INFORMATION

Name: _____
Address: _____

Phone: _____
Email: _____

ADDITIONAL INFORMATION

How did you hear about Harmar?

- Harmar Dealer
- Internet
- Magazine
Which: _____
- Friend or Acquaintance
- Saw Harmar product somewhere
- Other: _____

I purchased my Harmar lift because of:

- Style/Appearance
- Harmar Representative
- Previous Experience
- Ease of Use
- Recommendation
- Price/Value



WARRANTY

Page Intentionally Left Blank

NOTES



1500 Independence Blvd., Suite 220
Sarasota, FL 34234
800-833-0478
www.harmar.com