



Changing & Showering



standing • seating • desks • stools
toileting • bathing • changing • showering

supporting children and
their families for life

welcome

Since 1986, Smirthwaite has developed and retained its reputation as one of the leading designers & manufacturers of additional needs equipment. In that time, we've dedicated ourselves to finding and providing effective solutions that offer significant benefits to babies, children and young adults in their daily lives. Working closely with children, parents, caregivers and therapists, we have developed a comprehensive range of seating, standing, tables, desks, toileting, bathing, changing, showering, and therapy products.



Changing & Showering

Our range of disabled changing tables and showering products help users become more independent.

They're also designed to give carers confidence while working with the user.

We've taken great care to create a range of products that will help make your life simpler. For example, some of our disabled changing tables are mobile and need no installation.

We have products that are suitable for wet and dry conditions and for all budgets. We also have additional sizes available - please contact your local sales representative for further details.

Many of the products can be set to a safe and suitable working height to reduce the risk of back injury to the carer. This also applies to our wall mounted products.

Our changing and showering products are suitable for both children and adults. Plus, we offer a fitment service and various service plans to keep your products in tip-top condition.

Innovation in our design

Additional needs equipment is often overly complex, difficult to use and expensive to maintain. At Smirthwaite, we believe in well-made, easy to use products that stand the test of time. Through close consultation with leading therapists, parents and end users, we ensure our designs offer numerous clinical benefits whilst maintaining a customer-centric and innovative approach.

Warranty & servicing

All of our products come with a two year warranty as standard. An inspection, maintenance, service and repair facility for all Smirthwaite products is available to you, for complete peace of mind. This can be scheduled at a time that is convenient for you.

Call our Customer Services team today on **212 541 2455** or e-mail info@smirthwaite.com to book your service, inspection or repair.

Easy to clean

All of our products are easy to clean. For instance, our wooden chairs have anti-microbial properties that ensure surfaces are kept hygienic. This helps to reduce any risk of cross infection and is especially useful in multi-user environments such as nurseries and schools.

All our upholstery is carefully chosen due to its clever material make up that contains antibacterial agents that help against the spread of MRSA, E coli and other bacteria.

contents

changing & showering

easi-lift changing bench	4
hi-riser	6
hi-riser shower stretcher	8
mobi changer	10
mobi heavy duty changer	12
mobi shower trolley	14
shower stretcher fixed height	16
easi-lift shower stretcher	18

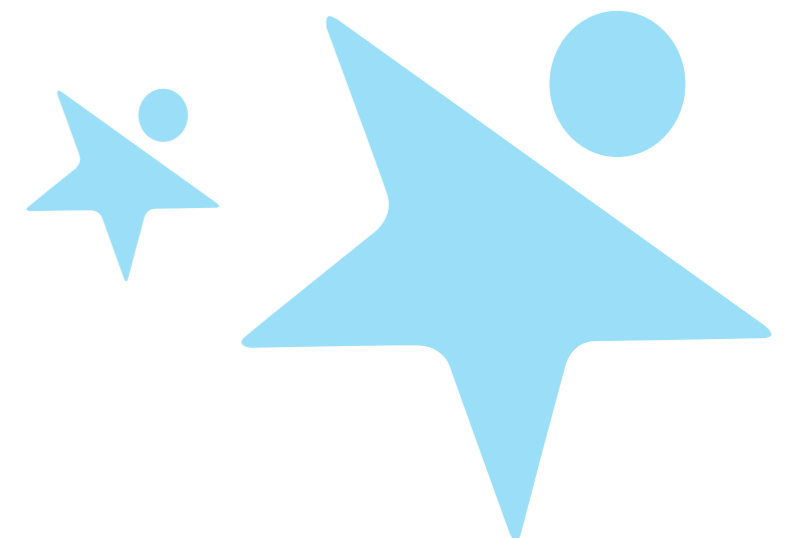

easi-lift changing bench



No floor fixing

Most height-adjustable changing tables require fitting to both the wall and floor. The Easi-Lift Changing Bench has been designed to require wall fixing only. This is particularly beneficial where the type of floor, surface pipe work or cabling prevent floor installation.

Reduces back injury

The Easi-Lift Changing Bench has a travel range of 17.7 - 37.4 inches to meet varying needs and the bench can easily be set to a safe and suitable working height to help prevent the risk of back injury to the caregiver.

Space saving design

Easi-Lift Changing Bench is a compact, electrically operated wall-mounted changing bench designed to fit in a dry room environment where space is at a minimum, folding away to save space after use.

Technical data

- No floor fixing required
- Weight capacity of 330lbs
- Travel range of 17.7 - 37.4 inches

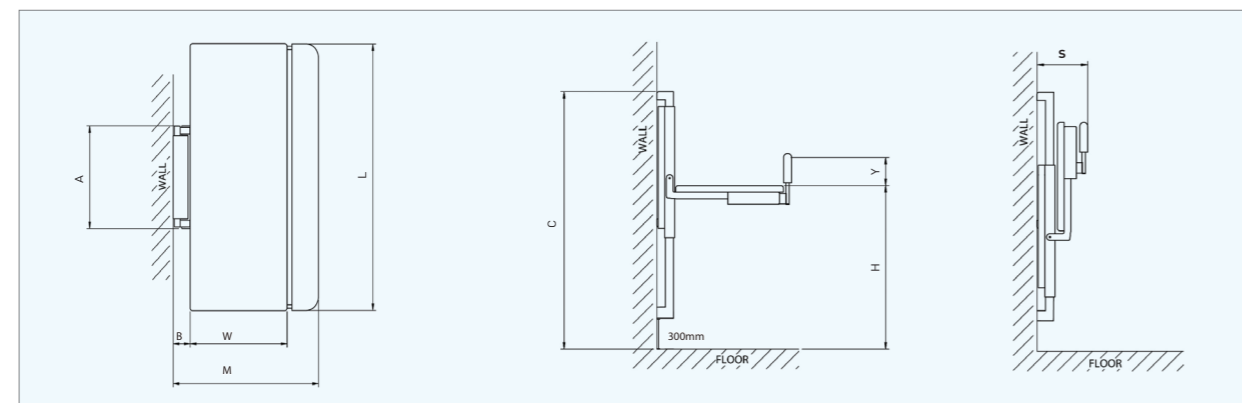
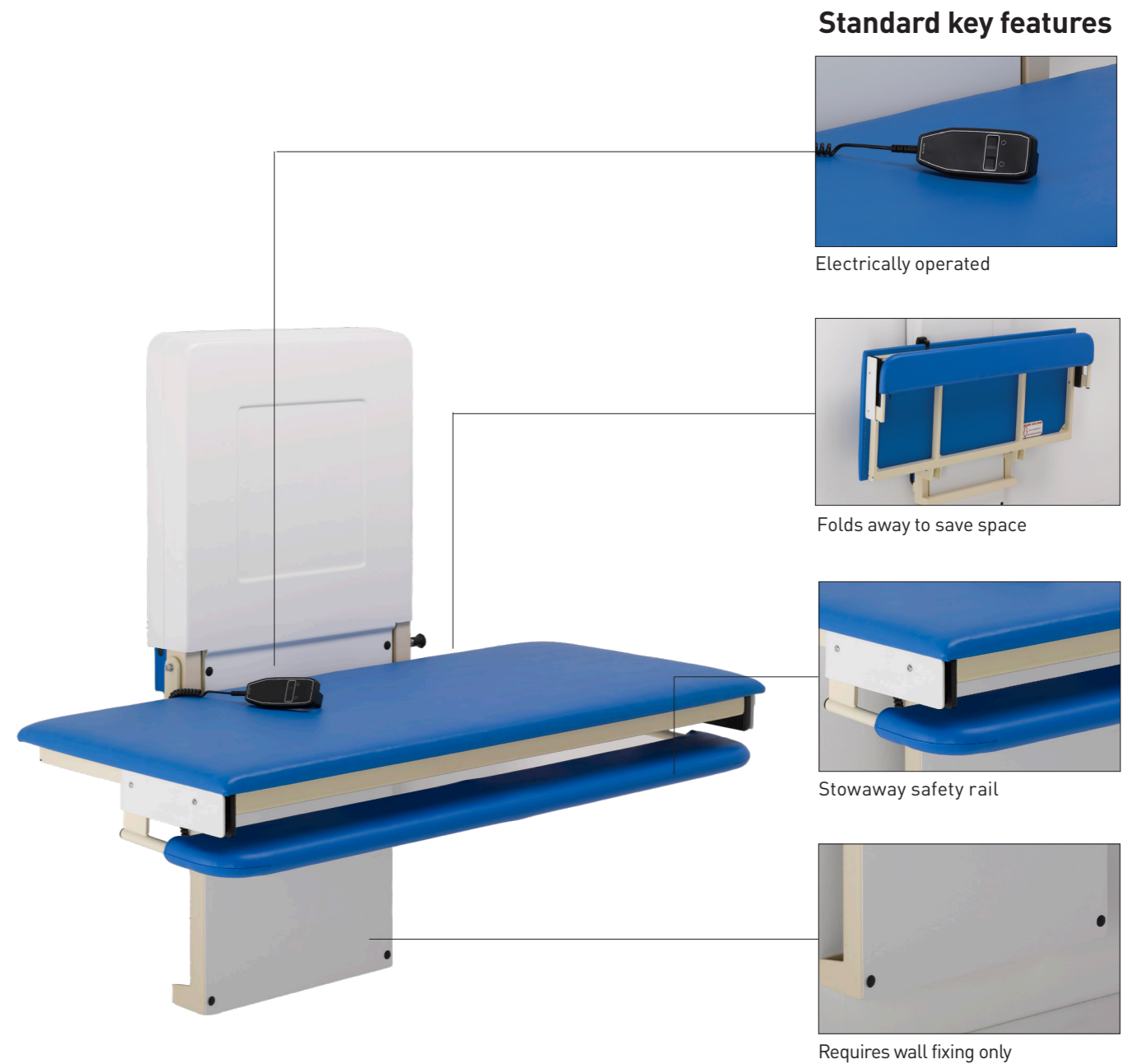

Code Item #	Size*	User Weight lbs	Table Dimensions			Travel Range H in	Wall Frame	Wall Frame	Wall Frame	Safety Side Height Y in	Stored Width S in
			L in	W in	M in		Width A in	Depth B in	Height C in		
3086	6	330	66.9	25.6	43.7	17.7 - 37.4	27.6	4.3	63.8	6.5	12.0

*Additional sizes are available on upon request - please contact your local sales representative.

hi-riser

(powder coated for dry rooms and stainless steel for bath rooms)



Robust yet slimline

Hi-Riser is an electrically operated wall-mounted changing table that is suitable for children and adults of up to 441lbs. Despite its robust structure, the Hi-Riser has a slimline design that ensures it fits easily into most environments.

Easy transfers

The Hi-Riser has been designed so that it can be used with most mobile or ceiling hoists. The unique safety side rail stows away, streamlining access for transfers from a wheelchair, shower and toileting chair. The Hi-Riser also benefits from an impressive travel range of 24in in height.

Providing options

We understand that every need is different, which is why the Hi-riser comes in seven different sizes that cater from young children through to adults. The Hi-Riser comes in a cream powder coated frame for dry-rooms or stainless steel frame for bath-rooms (not suitable for direct water contact).

hi-riser

key features

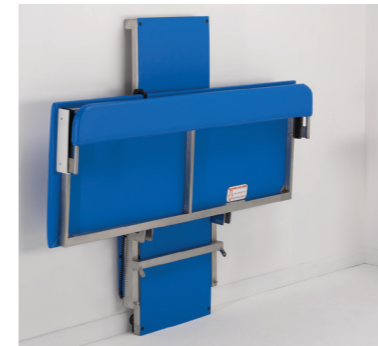

- Electrically operated
- Wall and floor mounted
- Cream powder coated frame for dry rooms
- Stainless steel for bath rooms
- Weight capacity of 441lbs
- Impressive travel range of 24"
- Folds away to save on space
- Easy to clean padded surfaces
- Wall mounting kit included
- Stowaway side rail

Mild Steel Powder Coated	Stainless Steel	Size	User Weight	Table Dimensions			Travel Range	Wall Frame Width	Wall Frame Depth	Wall Frame Height	Safety Side Height	Stored Width	Shipping Weight
Item #	Item #		lbs	L in	W in	M in	H in	A in	B in	C in	Y in	S in	lbs
3043	3053	3	441	55.1	23.6	36.4	15.7 - 39.4	27.6	4.3	61.0	6.5	12	185.2
3047	3057	7	441	70.9	25.6	38.4	15.7 - 39.4	27.6	4.3	61.0	6.5	12	202.8
3049	3059	9	441	82.6	25.6	38.4	15.7 - 39.4	27.6	4.3	61.0	6.5	12	212

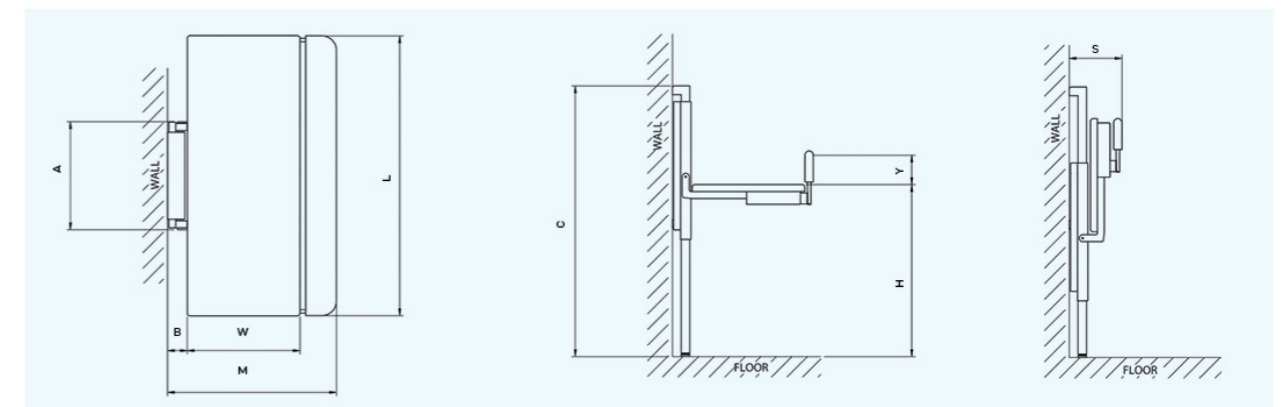

hi-riser shower stretcher



Two in one

The Hi-Riser shower stretcher is an easy to use two-in-one wall and floor mounted showering and changing table. Its robust yet slimline design makes it suitable for children and adults of up to 330lbs. Its versatility means it offers the ideal solution for swimming, hydrotherapy and bathroom environments.

Comfortable & hygienic

The Hi-Riser Shower Stretcher has been designed with reinforced PVC, making it highly supportive yet soft and comfortable to lie on. Its stainless steel frame facilitates easy cleaning, making it a perfect choice for multi-user environments.

Quick drainage

The Hi-Riser Shower Stretcher is supplied with flexible pipe work to use with a suitable floor drain or, alternatively, it can be plumbed in. Water can easily be drained away using the drainage pipe, which can also be detached for cleaning purposes.

hi-riser shower stretcher

key features

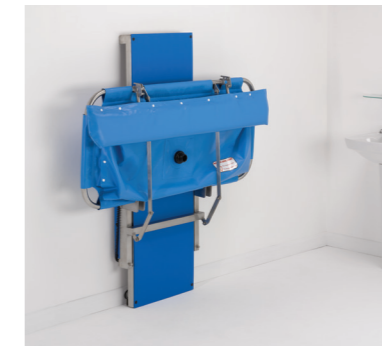

- Electrically operated – handset works safely in wet rooms
- Changing and showering in one
- Drainage pipe & fasteners included
- Wall and floor mounted
- Stainless steel construction
- Weight capacity of 331lbs
- Travel range of 22.4" in height
- Easy to clean padded surfaces
- Unique stowaway side rail
- Folds away to save on space
- Only protrudes 11.8" from the wall when stored

Shown on Easi-lift changing bench

Stainless Steel	Size*	User Weight	Table Dimensions			Travel Range	Wall Frame Width	Wall Frame Depth	Wall Frame Height	Safety Side Height	Stored Width	Shipping Weight
Item #		lbs	L in	W in	M in	H in	A in	B in	C in	Y in	S in	lbs
3067	2	331	70.9	25.6	43.7	15.4 - 37.8	27.6	4.3	61	6.5	11.8	181

*Additional sizes are available on upon request - please contact your local sales representative.

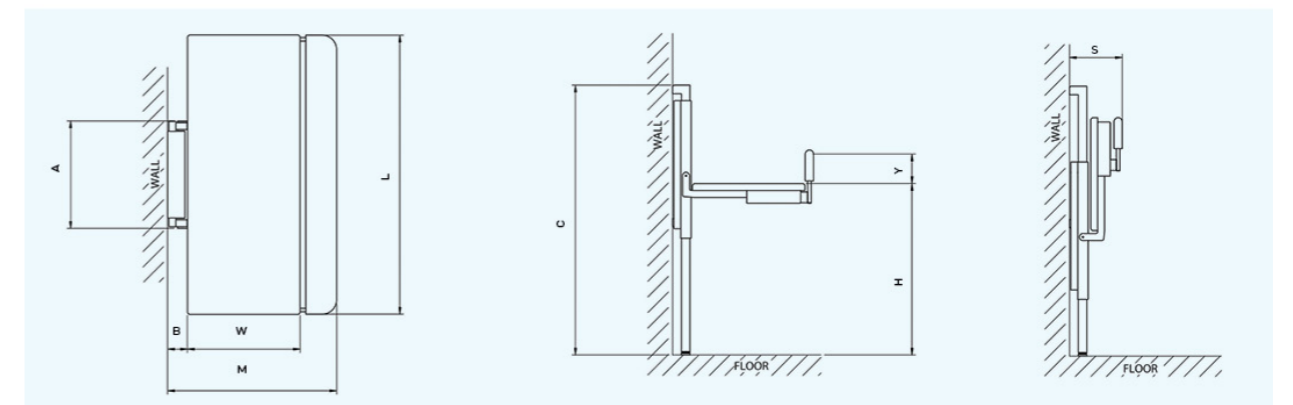

mobi changer



Room to room

The Mobi Changer is a fully mobile changing table that requires no installation or attachments. Its compact and slimline design means it can be easily maneuvered from room to room, offering an extremely cost effective option for multi-transfer or multi-user environments.

Height adjustable

The electrically operated Mobi Changer provides an excellent travel range of 37.4in in height and can be lowered and elevated at the touch of a button. Safe and suitable working heights can be easily achieved which helps prevent the risk of back injury to the caregiver.

Easy transfers

The Mobi Changer has been designed to ensure sufficient clearance for a wide number of hoists. Its mobility and unique stowaway side rails enable safe and easy handling. Whether you are transferring from a bed, wheelchair or toileting chair, the Mobi Changer is the perfect solution.

mobi changer

key features

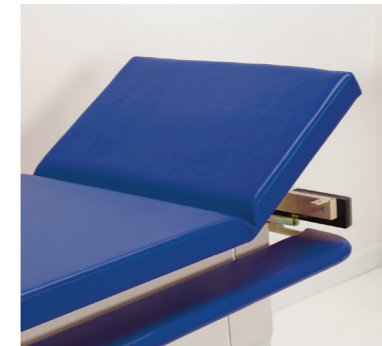

- Mobile and easy to maneuver
- No installation required
- Cream powder coated frame for dry rooms
- Stainless steel for wet rooms
- Available in 2 sizes
- Length of table available 55.1in or 70.9in
- Weight capacity of 500.4lbs
- Travel range of 37.4in in height
- Easy to clean padded surfaces
- Optional angled back
- Unique stowaway side rails

Mild Steel Powder Coated	Stainless Steel	Size	User Weight	Table Dimensions		Travel Range	Safety Sides		Safety Sides Operational Space	Castor Centres	Nominal Clearances	Shipping Weights	
Item #	Item #		lbs	L in	W in	H in	Width X in	Height Y in	Z in	P in	Q in	G in	lbs
3121	3141	1	500.4	55.1	29.5	18.5 - 37.4	33.1	6.5	7.9	42.9	27.6	7.5	189.6
3123	3143	3	500.4	70.9	29.5	18.5 - 37.4	33.1	6.5	7.9	42.9	27.6	7.5	198.4
3124	3144	4	500.4	78.7	29.5	18.5 - 37.4	33.1	6.5	7.9	42.9	27.6	7.5	220

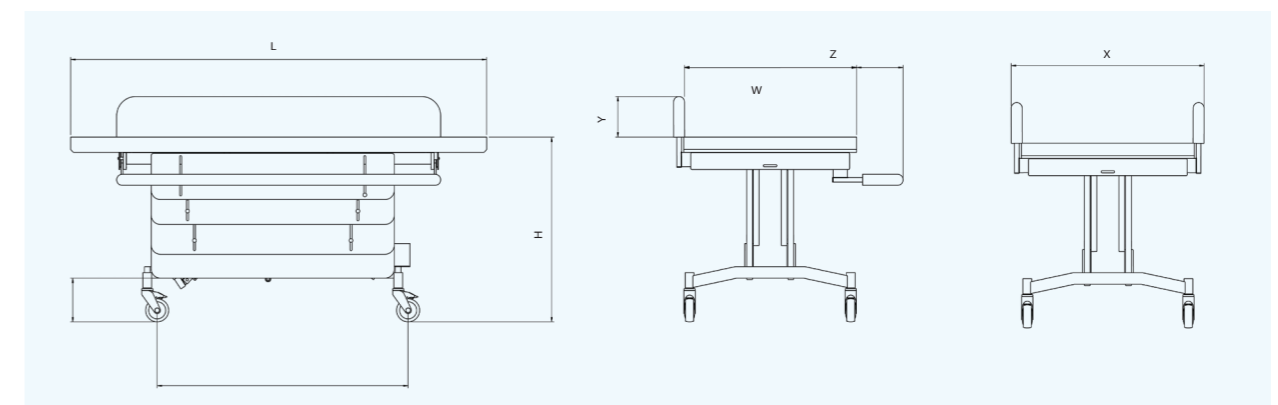

mobi heavy duty changer



Meeting bariatric needs

The Mobi Heavy Duty Changer has been designed to meet the needs of bariatric users. Its powerful 12K Newton motor, coupled with the extra wide mattress platform, makes it the ideal solution.

Maneuverability

The benefit of the Mobi range of products is that they do not require any wall mounting or floor attachments. They are easy to maneuver which means that the user can be transported from room to room with no trouble (door opening has to be 43.3in or more).

Height adjustable

The Mobi Heavy Duty Changer is electronically operated, which makes adjusting the height of the table simple, this is beneficial for both the caregiver and user.

mobi heavy duty changer

key features



- Mobile and easy to maneuver
- No installation required
- Electronically operated
- Cream powder coated frame for dry rooms only
- Length of table available in 78.7in
- Weight capacity of 1000lbs
- Travel range of 36.2in in height
- Easy to clean padded surfaces
- Unique stowaway side rails
- Wall mounted charger and 2 batteries come as standard

Mild Steel Powder Coated	Size	User Weight	Table Dimensions		Travel Range	Safety Sides		Safety Sides Operational Space	Castor Centres	Nominal Clearances	Shipping Weights	
Item #		lbs	L in	W in	H in	Width X in	Height Y in	Z in	P in	Q in	G in	lbs
3161	1	1000	78.7	37.8	21.7 - 36.2	41.3	6.5	7.9	59.1	31.5	5.9	220.5

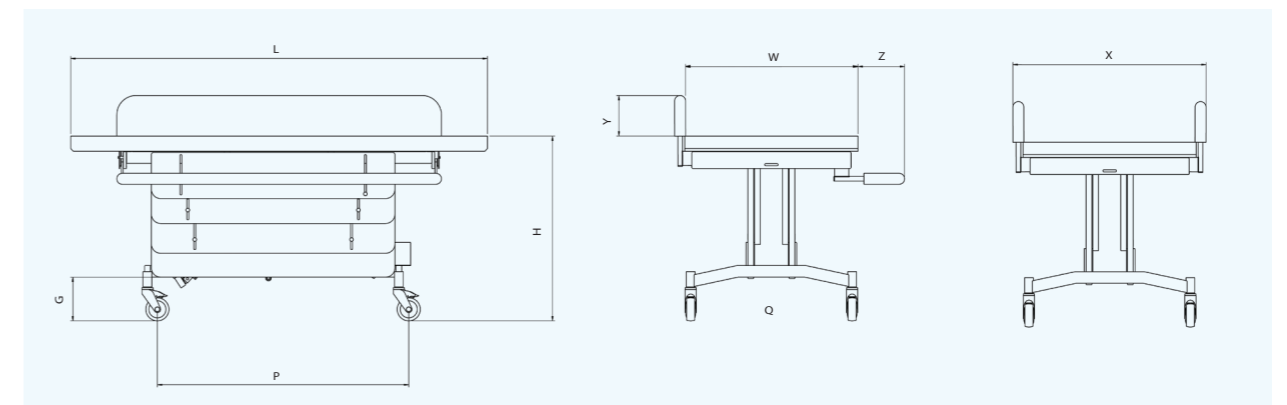

mobi shower trolley



mobi shower trolley

key features



- Mobile and easy to maneuver
- No installation required
- Stainless steel frame
- Drainage channel and pipe
- A soft comfortable mattress and wedge shaped pillow
- Available in 1 size
- Length of table is 70.9in
- Weight capacity of 485lbs
- Travel range of 36.4in in height
- Easy to clean padded surfaces
- Unique stowaway side rails

Stainless Steel	Size	User Weight	Table Dimensions		Travel Range	Safety Sides		Safety Sides Operational Space	Castor Centres		Nominal Clearances	Shipping Weights
Item #		lbs	L in	W in	H in	Width X in	Height Y in	Z in	P in	Q in	G in	lbs
3151	1	275.5	70.9	29.5	18.3 - 36.4	33.1	7.7	7.9	42.9	27.6	7.5	189.6

Safe showering

For many children and adults, conventional methods of bathing and showering can be difficult and even hazardous. The Mobi Shower Trolley is a powered, height-adjustable shower trolley specifically designed to enable the user to be safely and easily washed or showered by their caregiver.

Reduces back injury

The Mobi Shower Trolley offers a range of height adjustments to enable the caregiver to shower and change the user at a safe and suitable working height. This reduces the risk of back injury for the caregiver.

Stowaway side rails

The Mobi Shower Trolley has been designed with two unique safety side rails that can be easily stowed away beneath the trolley. This allows maximum clearance for safe, easy transfer and use.

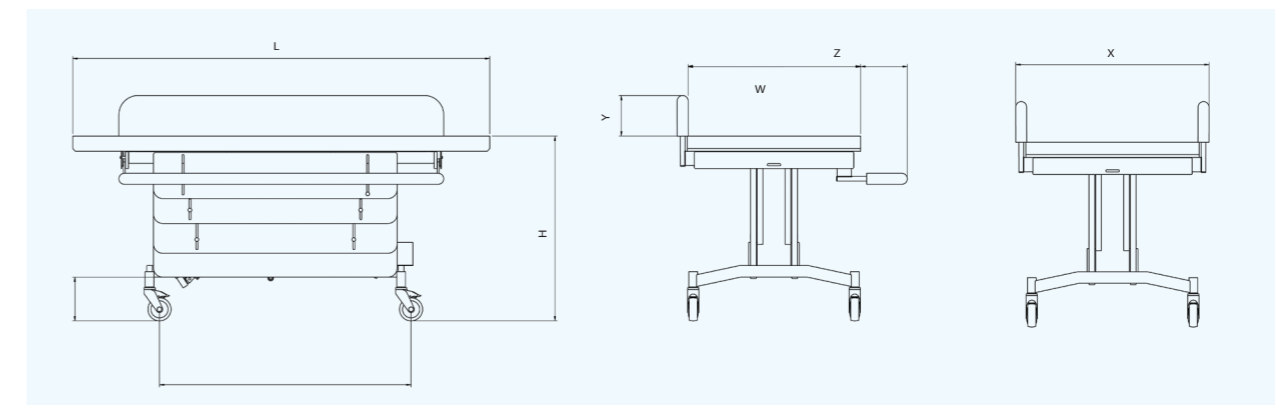

shower stretcher fixed height

shower stretcher fixed height

key features



- No floor attachments required
- Ideal for a wet room environment
- Stainless steel frame with powder coated finish
- Permanently fixed at the desired height
- Available in 2 sizes
- Length of stretcher available 55.1in & 74.8in
- Weight capacity of 440.9lbs
- Folds away to save on space
- Wipe clean surfaces
- Includes a safety guard

Stainless Steel Powder Coated		Size*	User Weight	Table Dimensions			Travel Range	Wall Frame Width	Wall Frame Depth	Stored Width	Product Weight
Without Headrest	With Headrest		lbs	L in	W in	M in	H in	A in	B in	S in	lbs
Item #	Item #										
3171	3271	1	440.9	55.1	25.6	39.4	Fixed	26.2	3.1	9.4in	165.3
3176	3276	6	440.9	74.8	25.6	39.4	Fixed	26.2	3.1	9.4in	176.4
3191	3291	1	440.9	55.1	25.6	39.4	Fixed	29.5	4.3	10.6	180.8
3196	3296	6	440.9	74.8	25.6	39.4	Fixed	29.5	4.3	10.6	191.9

*Additional sizes are available on upon request - please contact your local sales representative.

Economical solution

The Shower Stretcher Fixed Height is our entry-level product and an economical washing and showering solution for the user. This durable and slimline product represents real value for money.

Makes bathing easier

The Shower Stretcher Fixed Height is designed to allow the washing or showering of the user while in a horizontal position. It can be fixed directly above a bath making it the perfect solution for the home.

Added headrest

The Shower Stretcher Fixed Height, along with all of our shower stretchers, can be enhanced with the optional integral vinyl headrest. The headrest features a paddle lift adjustment, which allows it to be locked securely into the desired position.

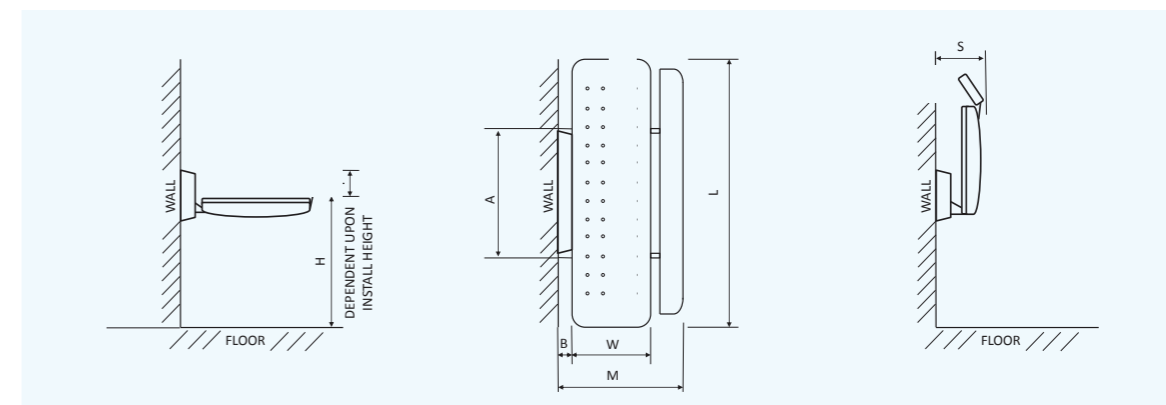

easi-lift shower-stretcher

Easy adjustment

The Easi-Lift Shower Stretcher has been designed to help you move the user up and down with ease whilst they are on the stretcher. It is electronically operated with a height range of 19.6in, which allows a safe and suitable working height to prevent the risk of back injury to the caregiver.

Contemporary design

The unobtrusive and neutral design of the Easi-Lift Shower Stretcher allows it to fit into a wide range of environments, especially with its stainless steel and powder coated frame. The need for floor fixing has been eliminated making it the perfect choice for areas where the floor type, surface pipe work or cabling

Easy storage

The compact design coupled with the ability to fold the stretcher away when it is not in use makes this the ideal product for times when space is limited.

Technical data

- No floor fixing required
- Weight capacity of 441 lbs
- Travel range 17.7 - 37.4 inches

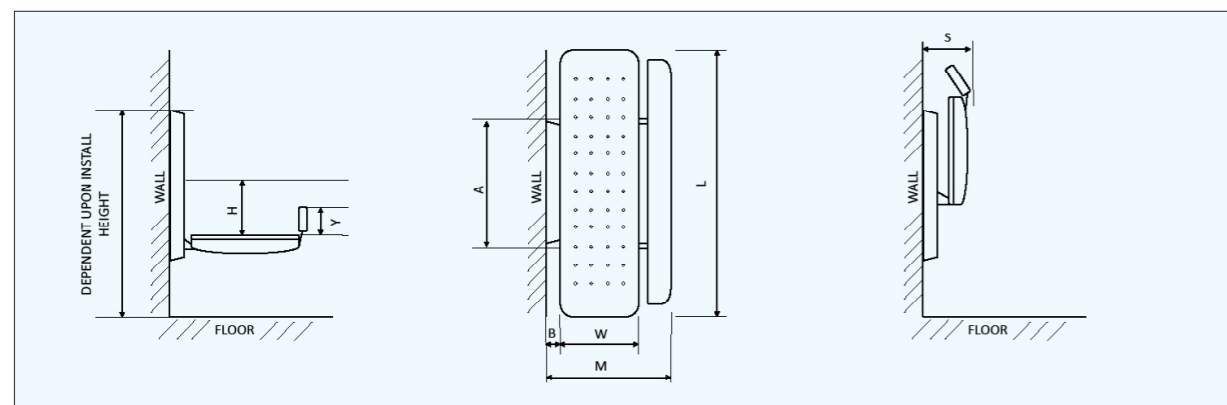

the ideal wet room product for times when space is limited



Picture shows optional safety guard



easi-lift shower-stretcher

Standard key features



Requires wall fixing only



Stainless steel frame with powder coated finish



Optional integral vinyl headrest



Folds away to save space

Colour



Stainless Steel Powder Coated	Size*	Table Dimensions			Travel Range	Wall Frame Width	Wall Frame Depth	Safety Guard Height**	Stored Width	Stored Width inc drip tray**	Max User Weight	Product Weight	
		L in	W in	M in									H in
Without Head-rest	3196	6	1900	650	1000	450 - 950*	750	110	145	270	380	200	87
With Head-rest	3296	6	1900	650	1000	450 - 950*	750	110	145	270	380	200	87

*dependent on installed height **optional accessory
 *Actual product may vary subject to design upgrades
 All technical data and drawings available on upon request.

*Additional sizes are available on upon request - please contact your local sales representative.

seating • standing • desks & stools • toileting & bathing • changing & showering

a helping hand around
the World



always here to help

USA Contact Details:

telephone

212 541 2455

email

info@smirthwaite.com

website

www.smirthwaite.com

Smirthwaite USA LLC

405 Lexington Avenue, 26th Floor

New York NY10174



Smirthwaite reserves the right to modify product specifications at anytime without prior notification.
All measurements are approximations and can vary depending on the wood and materials used.
All details shown are correct at time of print. Smirthwaite® is a registered trade mark of Smirthwaite Limited.